



Delivers the goods, deters theft



Kaiman® ALCs (Attached Lid Containers) incorporate an integral hinged lid and tamper-evident security to reduce losses and deter theft of high-risk or high-value goods in transit.

Features & Benefits

Product Protection

- Smooth internal surfaces & attached lid protect contents.
- Tamper-evident seals deter theft.

Ergonomics

- Wide contoured handholds strategically placed to reduce back injuries.
- Smooth surfaces.

Durable

- Strong and impact resistant.
- Containers typically stacked up to seven high carrying a unit load of up to 35 Kg.

Accurate identification

- RFID compatible.
- Tamper-proof drop-in card holders.
- Textured areas allow easy removal of adhesive labels.
- Recessed areas protects barcodes.
- Printing owner's logo and message promotes brand identity.

Economic & Ecologic

- Nesting to 75% saves valuable space on return transport.
- Unlike disposable packaging, LINPAC Allibert containers can be used again and again helping our customers comply with packaging waste legislation, reduce carbon footprint and save money.

Textured areas allow easy removal of adhesive labels without leaving a sticky residue

Integral lid cannot become separated from container and lost and inhibits theft when fitted with tamper-evident seals

Wide and comfortable hand-holds

Drop-in card label holders

Can be printed with owner's logo and message

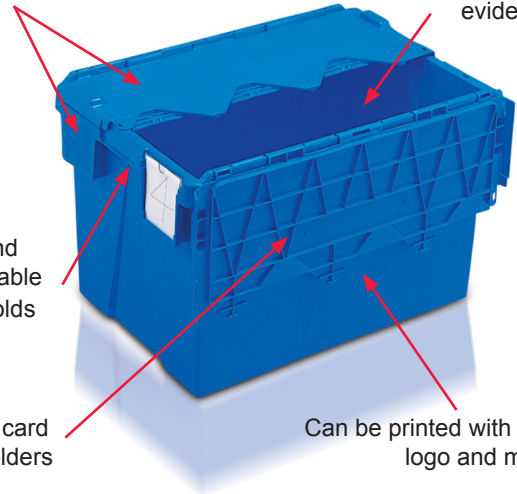

Tamper-evident seals protect contents from theft

No other name carries so much weight